

Sturm!

нас рекомендуют друзья

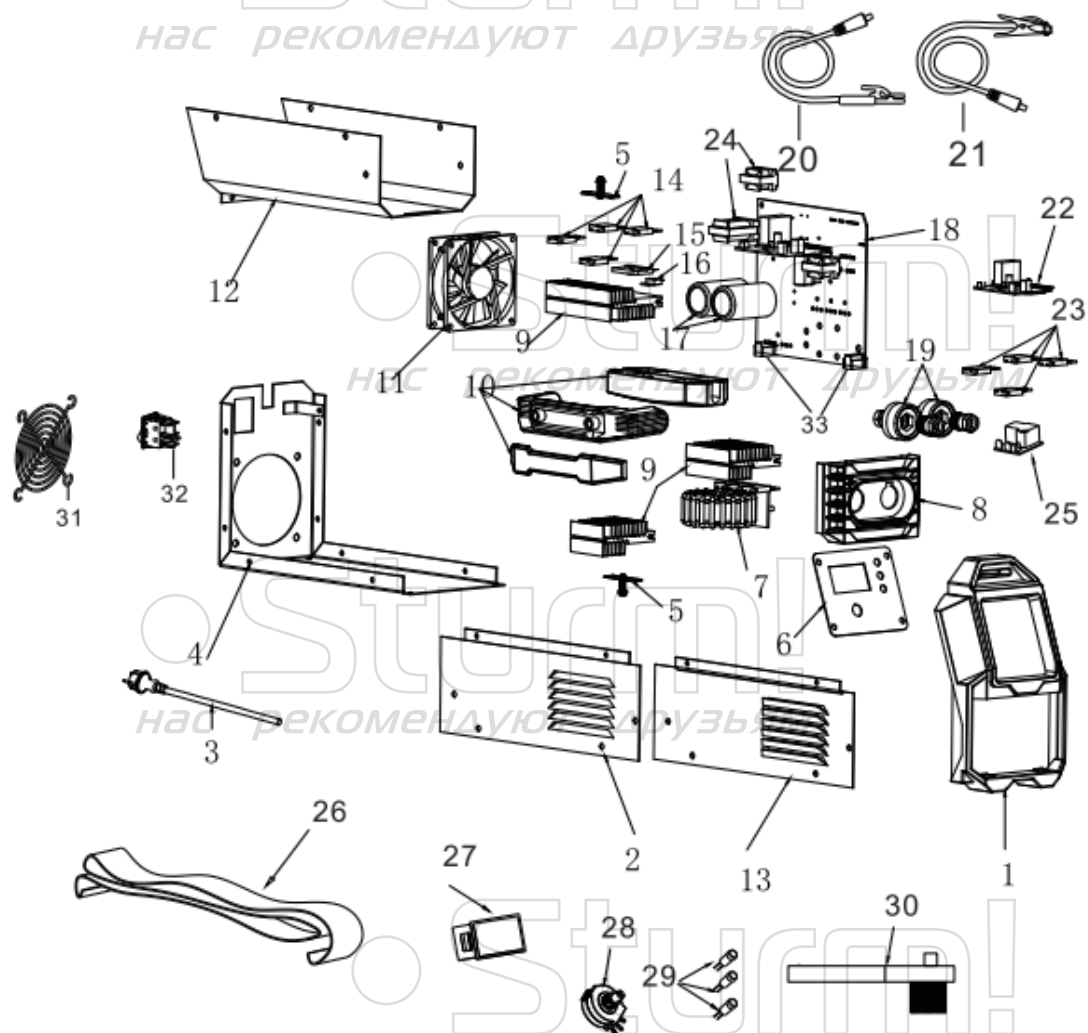

нас рекомендуют друзьям

AW971200, AW971250

No	Description	No	Description
1	Front of plastic panel	18	Whole pcb board with all component
2	Case on the left	19	Fast connector 10-25mm
3	Power cable 1.5m 2.5 ² Rubber	20	Earth clamp 300A with 14mm 1m
4	Case on the bottom	21	Electrode holder 200A with 14mm 2m
5	Pressing plate	22	Signal board PKB-200
6	Front of metal panel	23	Fast recovery diode SL25U20
7	Main Transformer T56X28X20 25:5	24	Small transformer set
8	Front of plastic for cooling	25	Relay 30A
9	Radiator (25Y circuit board)	26	Belt 1,5m
10	Plastic handle	27	Display board
11	Fan high speed 5000 RPM	28	Potentiometer
12	Case on the beside	29	LED Lamp
13	Case on the right	30	Steel brush
14	IGBT SL20N60PFD	31	Fan net
15	Rectifier bridge D35SB100	32	Power switch JD03-A1 30A
16	NTC 90 °C	33	Rubber foot
17	Capacitor 390UF/400V 85°C		

RU-ST20200925

Sturm!
нас рекомендуют друзьям

Sturm!
нас рекомендуют друзьям

AW971200 FRONT-BOARD

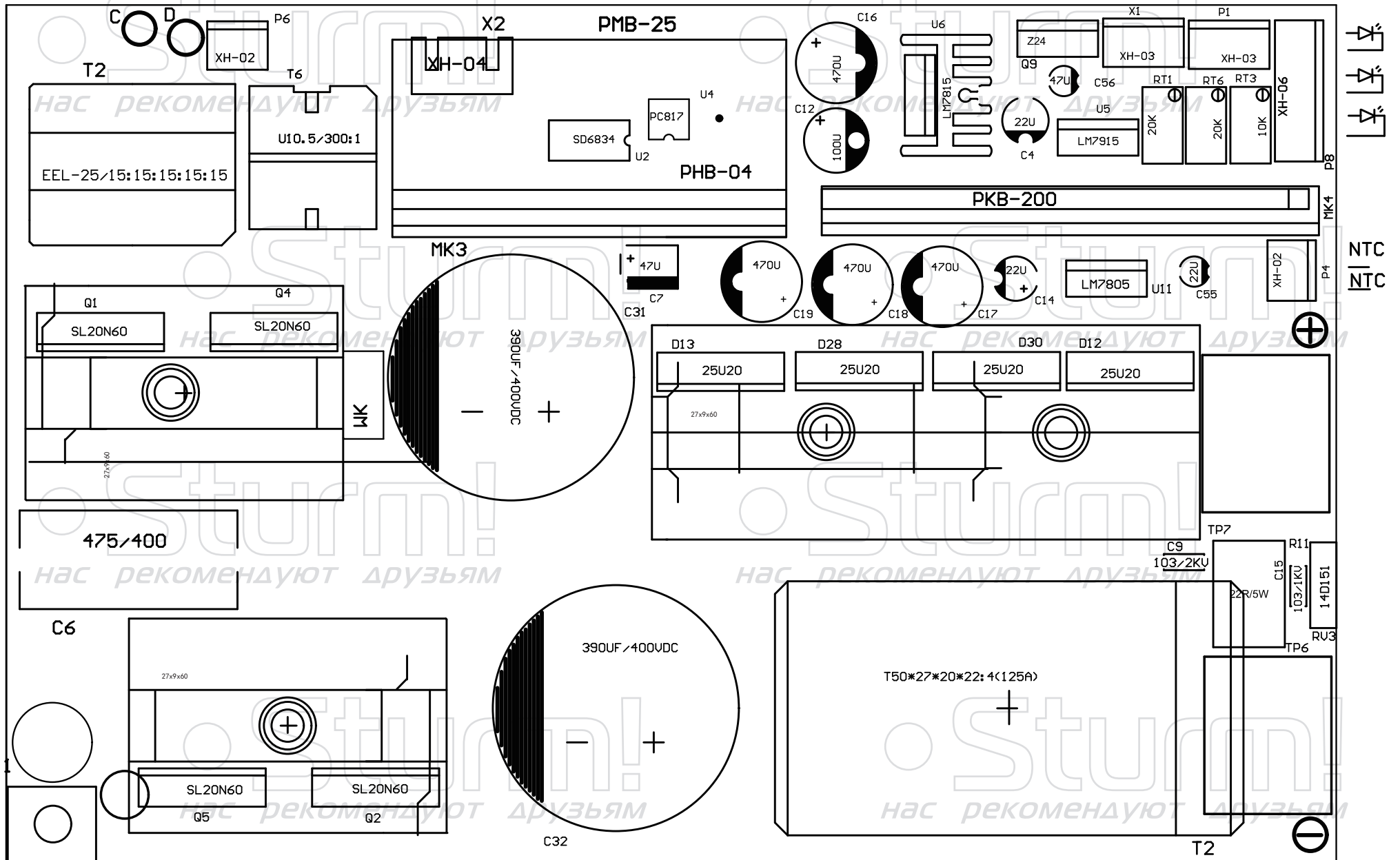

NTC
|
NTC



String

AW97I250 FRONT-BOARD

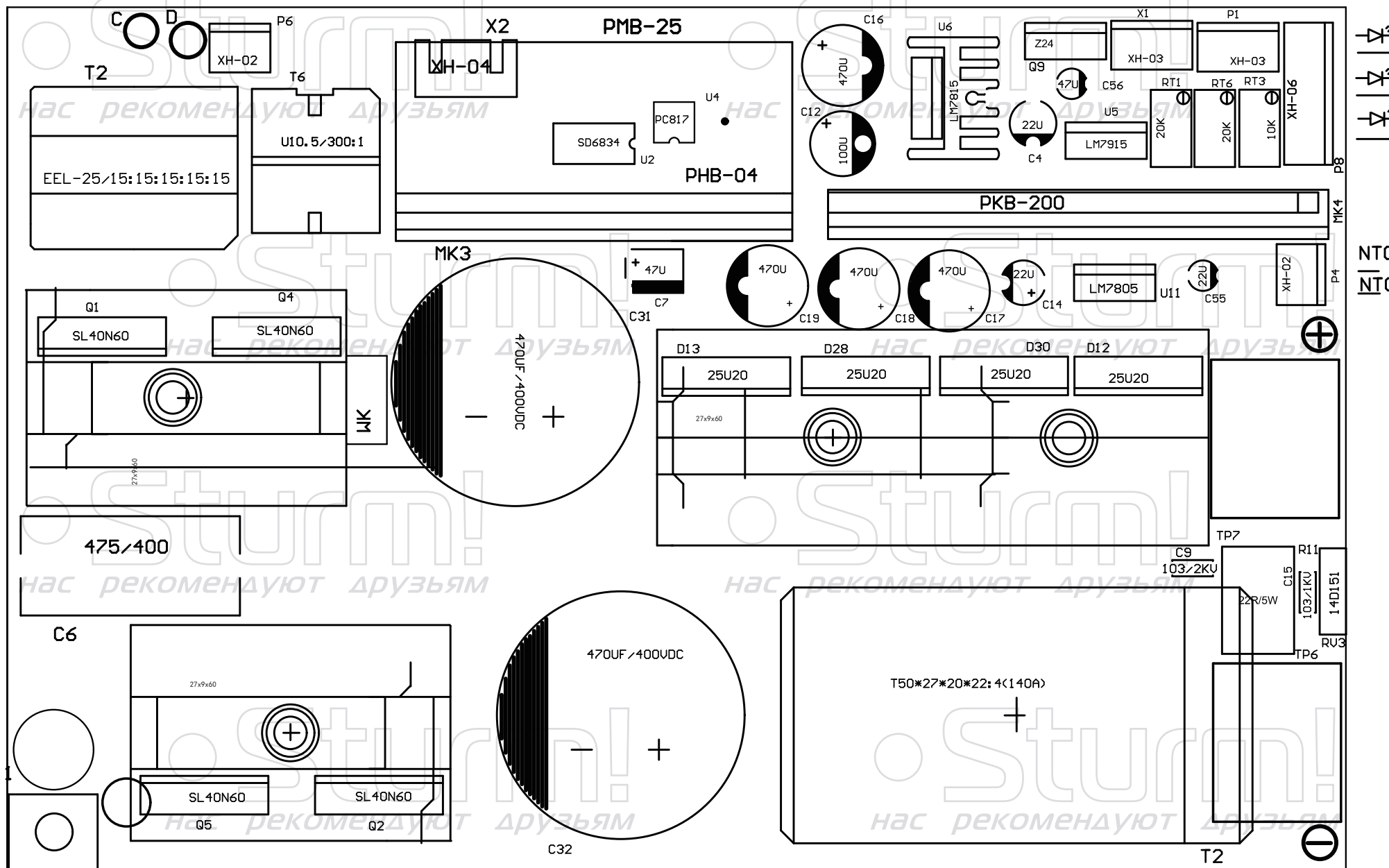

NTC
NTC



String

AW97I200,AW97I250 BACK-BOARD

